



Catalogue :

**SERIE 900 KORE**

Chapter :

**FRYERS 900 KORE**

Article :

**F-E9121 380...415V 3N 50/60Hz 2C**

Code:

**19034071**

<u>DIMENSIONS AND WEIGHTS</u>		<u>Net dimensions</u>	<u>Packed</u>
Length	mm	<b>400,00</b>	<b>1.022,00</b>
Depth	mm	<b>930,00</b>	<b>440,00</b>
Height	mm	<b>850,00</b>	<b>1.115,00</b>
Weight	kg	<b>75,00</b>	<b>90,00</b>
Volume	m3	<b>0,36</b>	<b>0,50</b>
<u>ELECTRICITY</u>		<b>380...415V</b>	<b>50/60Hz</b>
	Power		<b>15,00 kW</b>
Connections	230 V. I+N+T		
	230 V. III+T		
	400 V. III+N+T	<b>4X4MM2+T</b>	
<u>GAS</u>	Not necessary		
<u>WATER</u>	Not necessary		
<u>STEAM</u>	Not necessary		
<u>AIR</u>	Not necessary		

DESCRIPTION

ELECTRIC DEEP FAT FRYER, F-E9121  
 Fryers are designed to deep fry large amounts of product (chips, croquettes, different types of dredgings, etc.).  
 2 mm stainless AISI-304 steel top with rounded edges for easy cleaning.  
 Laser cut and automatic welding for a perfect adjustment of sides between modules with square angle finish.  
 Number of wells: 1.  
 Well capacity: 21 litres.  
 Standard equipment: Two 132x338x132 mm baskets.  
 Well integrated in the top, with cool area at the bottom. This helps to maintain oil properties and quality for a longer time.  
 Heating by means of AISI 304 stainless steel electrical resistances inside the well. They can be tilted more than 90° for a perfect cleaning.  
 High power/litre rate: 0.857 kW per litre.  
 Thermostat for temperature control (between 60 and 200°C).  
 Safety thermostat.  
 Oil discharge through robust and reliable high temperature resistant ball tap.  
 Fitted with independent lids for each well.  
 Basket drainage support at the back of the well.  
 Water-tight and protecting-support controls.  
 High temperature protector for the chimney made of enamelled cast iron.  
 Front access to components.  
 According to European standards for components and panels temperature, efficiencies and combustion, and sanitary regulations (EN-60335 and EN-203)  
 IPX5 grade water protection equipment.  
 Maximum power: 18.0 kW.  
 Dimensions: 400 x 930 x 850 mm.

SOUND LEVEL < **65,00** db

INSTALLATION - CONNECTIONS

► ELECTRICITY SI Ø





Catalogue :

**SERIE 900 KORE**

Chapter :

**FRYERS 900 KORE**

Article :

**F-E9121 380...415V 3N 50/60Hz 2C**

Code :

**19034071**

**SCHEMA - DIMENSIONS**

**F-E9115 & F-E9121**

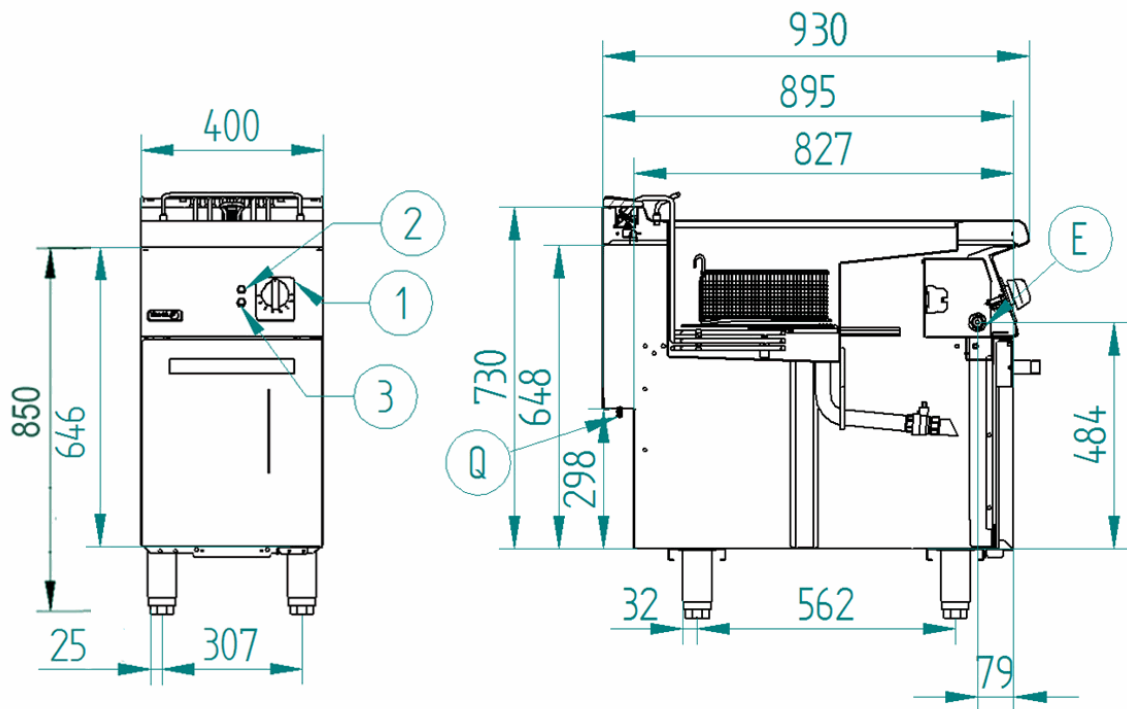

E – Conexión eléctrica

Q – Conexión equipotencial

1 – Mando termostato

2 – Piloto verde

3 – Piloto ambar

Electrical connection

Equipotential connection

Thermostat control

Green pilot

Ambar pilot

